



Released Test Form
Spring 2000
Grade 8
Form 28



Georgia Department of Education
Linda C. Schrenko, State Superintendent of Schools

Reading

Directions:

Today you will be taking the *Reading Criterion-Referenced Competency Test*. The Reading test consists of multiple-choice questions. Sample questions have been included. Look at the directions for the multiple-choice questions.

There are several important things to remember:

- 1** Read each passage carefully. You may look back at the reading passage as often as necessary.
- 2** Read each question carefully and think about the answer. Then choose the answer that you think is best and fill in the circle for your answer on your answer sheet.
- 3** If you do not know the answer to a question, skip it and go on. You may return to it later if you have time.
- 4** Fill in the correct circle for your answers on your answer sheet only.

Sample Multiple-Choice Questions

Look at the sample test items that follow. These items will show you what the questions in the test are like and how to fill in your answers on your answer sheet. For this type of question, you will select the answer and fill in the circle in the space on your answer sheet for the answer you have chosen.

Delivering the Mail

Many people think that the pony express was the earliest mail delivery service, but stagecoaches carried the mail first. The pony express carried only light mail (short messages and letters). This delivery system lasted only two years because telegraph lines were built and short messages no longer had to be carried as mail. However, stagecoaches continued to carry heavier mail because they still had passengers to keep their business alive. Later, railroads were built and trains took over the job of carrying the mail. Even mail delivery by railroad was replaced in part by the airplane.

Sample 1

What is the main idea of this passage?

- A The pony express delivered the mail for two years.
- B The airplane is the best way to deliver the mail today.
- C The railroads took over the job of delivering mail.
- D The way mail is delivered has changed over time.

Sample 2

Which of the following carried the mail FIRST?

- A stagecoaches
- B pony express
- C trains
- D airplanes

235 Second St.
Huntsville, AL 35801
August 29

Dear Joe,

Hi! How are you? Did you do anything special for summer vacation? In August, my family toured the Capitol and other awesome sites in Washington, D.C. It was great. We stayed about five miles outside of town and took the train to the city almost daily for a week. On the first day we visited Congress. We toured the Senate and got to sit down in chairs that overlooked the Senate floor. Our guide explained how senators vote and how the vice president presides as president of the Senate. After that, Mom treated me to lunch at the Congressional Dining Room. It's this very old and elegant restaurant with white linen tablecloths, crystal chandeliers, and walls painted dark blue. We saw two senators eating lunch that afternoon.

Later, we visited the Library of Congress. Did you know you can get a library card there? It's not as easy as at our library though. You have to go through a back entrance and register by computer. Then you get the card, but you can't check out books unless you're a member of Congress. So Mom and I browsed the shelves. By the time we finished, we were ready for dinner, so we took the Metro subway to a restaurant for almond chicken.

The family rested up that night because we planned to see the Smithsonian Institution, and we knew that would take all of the next day. Dad and I went to the Museum of American History where we saw the original flag, Old Glory. That's the flag Francis Scott Key saw flying over Fort McHenry when the British attacked the United States during the War of 1812. He was so proud to see that the Americans had survived the battle that he wrote the Star-Spangled Banner. That's why we sing, "Oh, say, does that star-spangled banner yet wave/O'er the land of the free and the home of the brave."

We toured the White House last. We saw the State Dining Room, where the president holds formal dinner gatherings, and the Blue Room, which serves as a reception room for visitors and guests. I thought we'd get to see the whole house, but tourists aren't allowed to visit above the first floor.

I can't wait to visit Washington again. Next time I want to tour the F.B.I. building and visit Ford's Theater, where President Lincoln was assassinated while watching a play. I hope you can visit the capital someday. I know you'd love it. Please write back.

Sincerely,

Chen Lee

- 1** On vacation, Chen Lee's family visited the capital city
- A** every Wednesday
 - B** on the first day
 - C** almost every day
 - D** only at night
- 2** The last sight Chen Lee's family saw was
- A** Old Glory
 - B** Ford's theater
 - C** the Smithsonian
 - D** the White House
- 3** Which of the following is Chen's opinion?
- A** We toured some awesome sites while on vacation.
 - B** The vice president presides as president of the Senate.
 - C** We stayed in a hotel just five miles out of town.
 - D** The Museum of American History displays "Old Glory."
- 4** The word *presides* means
- A** gives an account of something
 - B** holds a position of authority
 - C** guarantees
 - D** dramatizes
- 5** An example of a compound word is
- A** original
 - B** entrance
 - C** overlook
 - D** register
- 6** The root word of *vacation* is
- A** vacant
 - B** vacate
 - C** cat
 - D** vacating

**LINK/FIELD TEST READING
PASSAGE**

7 LINK/FIELD TEST ITEM

9 LINK/FIELD TEST ITEM

8 LINK/FIELD TEST ITEM

10 LINK/FIELD TEST ITEM

Oral History—A Lifetime of Memories

As children, we paid rapt attention to our parents' stories of growing up, and our grandparents often had even better tales of their long-ago childhoods. Elderly friends and neighbors, too, can reveal glimpses into the past.

Most of these walking history books would love to spin tales for the future. They need only be given a means, and it is not hard to provide that means. To make an oral history, one need only have a person with a story to tell, a list of questions, and a recording device, which can be a pen and paper, a tape recorder, or a videotape recorder.

First, approach the person you would like to record. Ask if they would mind talking with you about their view of history, their childhood, and/or what they have learned in life. Most older folks would gladly agree—they are generally eager to talk. Be certain to mention reasons why you want to record their story—these can range from needing the information for a class to curiosity about life in the past. After your subject has agreed to a time and place, let the subject know what you would like to hear about.

Prepare your questions in advance, and keep to your specific topic. Most oral histories will require several sessions. It is wise to begin each session with easy questions. These include asking about the subject's age, birthplace, family members, and other factual topics. These are known as closed questions; they ask for simple, factual answers.

After the closed questions are finished and the subject is comfortable with the interview, you can begin asking open questions. These questions will not have a simple answer; they usually begin with "how" or "why." An open question would be: "Why did your family move from the farm to the city?" Be alert to the subject's answers—you may set aside your planned questions if a surprise arises. For example, if the subject tells you that her family moved to the city to live with a rich uncle who was a sea captain, you could question her about the change in lifestyle and her uncle's occupation. At the close of each session, you should thank the subject for participating and set up a later interview session. Mention the topic for the next session.

Your first session will probably be about the subject's family tree and childhood. Later sessions could include questions on teenage years and young adulthood. You can also ask about parenthood, middle age, old age, historical events, and personal views. Remember to begin each session with closed questions, then move on to open questions.

As the sessions come to an end, you and your subject will know each other much better than before. In recording a history, you may make a lasting friend.

- 11** Why is it wise to begin the interview with easy questions?
- A The subject will probably know the answers.
 - B Easy questions put the subject at ease.
 - C They are unlikely to offend anyone.
 - D The interviewer can remember them best.
- 12** Paragraph 3 of the passage is mainly about
- A possible topics for sessions
 - B constructing questions
 - C convincing someone to be interviewed
 - D whom to talk to
- 13** Which of these is an example of a *closed question*?
- A Why did you become a teacher?
 - B Where were you born?
 - C How did you feel about the war?
 - D Why didn't you like the new town?
- 14** When explaining this passage to someone else, which of these steps would be the **LEAST** important?
- A finding a subject for the interview
 - B constructing the questions
 - C setting up the interview
 - D getting a pen and some paper
- 15** The last paragraph of the passage would be stronger if
- A it included a summary
 - B it gave tips on how to be a friend
 - C it ended with an open question
 - D the author gave an example

LINK/FIELD TEST READING PASSAGE

16 LINK/FIELD TEST ITEM

19 LINK/FIELD TEST ITEM

17 LINK/FIELD TEST ITEM

20 LINK/FIELD TEST ITEM

18 LINK/FIELD TEST ITEM

Glasses and Me

by Lola Sneyd

I scratch them
I lose them
I sit on them
I break them
and sometimes
when I want to see streetlights
without their gauzy halos
brilliant stars
pin-pricking the ebony sky
yellow-green
leaf buds on trees
a rainbow mosaic
of wild meadow flowers
the yellow and black
striped fuzzy hair
on a wiggling caterpillar
and your smile across the room

I wear them

21 What problem does the author have in the passage?

- A She likes wearing glasses.
- B She doesn't like seeing well.
- C She can't see well without glasses.
- D She likes to see things without glasses.

22 Why does the author mention flowers?

- A She likes to smell them.
- B They are one thing she likes to see.
- C She likes things of a certain color.
- D Flowers are given as gifts to others.

23 How are a caterpillar and stars alike?

- A They are easily seen.
- B The poet needs glasses to see them.
- C People don't usually notice them.
- D They aren't pretty to look at.

24 Which words BEST suggest how the streetlights probably look if the author isn't wearing glasses?

- A huge and glaring
- B small but clear
- C hazy and vague
- D flickering and bright

25 What is the author's main purpose for writing this passage?

- A to describe some places she's seen
- B to explain why she wears glasses
- C to tell a funny story about glasses
- D to list some facts about glasses

***Strikeout Pitcher* a Hit!**

The latest novel in the Varsity Sports series by Dana Fletcher is titled *Strikeout Pitcher*. After winning the league title, the Painterville Lions team qualifies for the first round of the state high school softball playoffs. Strange events begin to occur, and the softball team faces a series of mysteries on their path to victory.

During practice for the first playoff game, items begin to disappear: team bats, catcher's equipment, an outfielder's glove, and lots of other stuff. Even the team mascot, a giant stuffed lion named Goldie, vanishes. At practice, starting catcher Audrey Wilks steps into a hole in front of home plate and sprains an ankle. To make matters worse, on the way to the first playoff game, Coach Paxton's car breaks down.

Who is responsible for the missing softball equipment? How did a hole get on the home field? Could a player be preventing them from winning? Maybe a teammate who's involved? The mystery builds as the team makes it to the first playoff game with a volunteer parent as coach and a rookie catcher, who acts like my friend Tom Sills, behind the plate. Minutes before the first pitch, Coach Paxton makes it to the sidelines for an inspirational speech, and the game begins. The writer maintains suspense throughout the story, and all the riddles are solved by the last pitch. The events at practice are even a bit humorous.

Strikeout Pitcher provides a nice read for the true sports fan, especially one interested in softball. The plot is realistic, the characters ring true, and the last chapter has a thrilling end.

26 Why does the author ask questions in the third paragraph?

- A to make you think about the plot
- B to tell you the solution
- C to analyze softball
- D to describe the softball fan

27 The last paragraph is written as

- A a solution
- B a chronology
- C a summary
- D a comparison

28 The purpose of this passage is to

- A debate
- B argue
- C compare
- D analyze

ATTENTION 7th AND 8th GRADERS!

SPECIAL WORKSHOP

Writing
Short Stories
for Publication

Sign up before Wednesday, September 26,

to attend the classes

Classes to be held every
Thursday in October
from 7:00 P.M.–8:30 P.M.
in the media center
at Graham Middle School

**Local author Mary Jean Botten will
be the instructor

29 What is this passage mostly about?

- A a reading workshop
- B a workshop on the writing process
- C a course on the short story
- D classes for short story writers

30 Where will classes be held?

- A Graham Middle School
- B information not given
- C the county media center
- D Ms. Botten's classroom

31 In the last line of this passage, Mary Jean Botten is identified as a local author. The purpose of this is

- A to sell her books in local bookstores
- B to tell her neighbors she's in town
- C to use her celebrity status to encourage participation
- D to show off the town's author

LINK/FIELD TEST READING PASSAGE

32 LINK/FIELD TEST ITEM

35 LINK/FIELD TEST ITEM

33 LINK/FIELD TEST ITEM

36 LINK/FIELD TEST ITEM

34 LINK/FIELD TEST ITEM

LINK/FIELD TEST READING PASSAGE

37 LINK/FIELD TEST ITEM

38 LINK/FIELD TEST ITEM

39 LINK/FIELD TEST ITEM

40 LINK/FIELD TEST ITEM

41 LINK/FIELD TEST ITEM

42 LINK/FIELD TEST ITEM

Anansi and Common Sense

Anansi the Spider was a tricky guy. Stories about his trickiness have spread all the way from West Africa to the Caribbean Islands. This particular story comes from the Caribbean Island of Jamaica. In fact, Anansi was such a trickster that he often found himself doing things that even tricked himself.

Once Anansi got to thinking about all the tricks he had tried to play on people in the past, and it occurred to him that a lot of his tricks had not worked at all because people had used a little bit of common sense to keep from being tricked. Common sense! What an annoyance! The more he thought about it, the more annoyed he became. All of those perfectly good tricks, ruined! And a lot of them had taken much time and effort to set up! What an inconvenience it was to have people going around using common sense all of the time to solve their problems and avoid his tricks.

Anansi thought about the problem of common sense for a long time. He began to scheme and plan a really tricky trick. He reasoned that since he was a special being, he should be able to gather up all the pieces of common sense that he found and hide them away inside a big calabash gourd.

So that is what he did. He very carefully picked up every piece of common sense that he found and hid it inside the calabash.

Anansi was sure that when people realized that they had no more common sense, they would come to him for advice and guidance. He, of course, would oblige them for a fee and soon he would be very rich.

On and on he went, reaching through open windows, into drainpipes, looking everywhere for scraps of common sense. It was an immense task, and it took him a very long time, but finally he felt that he had all the common sense in the world safely tucked away inside the calabash where no one could get at it.

But to make doubly sure that common sense was hidden away for good, Anansi decided to hide the calabash at the top of a tall palm tree where it would never be found again. He tied a string to the calabash and hung it around his neck in front of him to make sure none of the common sense spilled out on the way up the tree.

Anansi began to climb the palm tree. Normally, he was a fairly good climber, what with the extra legs and all, but this time he really had to struggle to get up the trunk of the palm. Each time he tried to pull himself up a little farther, the calabash would bump against his chest and he would slide down a little. At this rate, he would have to climb all day!

Anansi was getting more and more frustrated when all at once, he heard a loud laugh from behind him. He turned to see a boy laughing at him.

“Foolish Anansi! What’s the matter with you? You will have to hang that big calabash around your neck behind you if you expect to be able to carry it as you climb that palm.”

Anansi was furious to hear this completely unexpected bit of excellent common sense from the boy, especially after thinking that he had gathered up and hidden all the common sense in the world. He took the calabash and smashed it to pieces, sending little bits of common sense flying back all through the world. He walked away muttering to himself.

So, thanks to Anansi cleverly tricking himself, everyone in the world has a little bit of common sense and nobody has it all!

43 “Anansi and Common Sense” is

- A an essay
- B a biography
- C a poem
- D a folk tale

44 What was the **FIRST** thing Anansi did about the problem of common sense?

- A He planned a trick.
- B He gathered up the pieces.
- C He thought about the problem.
- D He hid all of the pieces.

45 Anansi is a(n) _____ guy.

- A tricky
- B smart
- C amusing
- D lazy

46 The purpose of this story is

- A to entertain
- B to debate
- C to inform
- D to analyze

47 Which would be the BEST place to dock a boat and then take the train to Stote?

- A Kramer
- B Highview
- C Farwell
- D Raston

48 Which of the following is a logical conclusion to draw about the city of Raston?

- A It has a beautiful view of the river.
- B It is a good location for shipping goods.
- C It offers a wide variety of cultural activities.
- D It is the second largest city in the state.

49 Why was this map made?

- A to persuade
- B to debate
- C to inform
- D to entertain

You do not need to use the passage to answer question 50.

50 Which word BEST completes the analogy?

shallow is to deep as filmy is to _____

- A clear
- B muted
- C depth
- D milky

English/Language Arts

Directions:

Today you will be taking the *English/Language Arts Criterion-Referenced Competency Test*. The English/Language Arts test consists of multiple-choice questions. Sample questions have been included. Look at the directions for the multiple-choice questions.

There are several important things to remember:

- 1** Read each question carefully and think about the answer. Then choose the answer that you think is best and fill in the circle for your answer on your answer sheet.
- 2** If you do not know the answer to a question, skip it and go on. You may return to it later if you have time.
- 3** Fill in the correct circle for your answers on your answer sheet only.

Sample Multiple-Choice Questions

Look at the sample test items that follow. These items will show you what the questions in the test are like and how to fill in your answers on your answer sheet. For this type of question, you will select the answer and fill in the circle in the space on your answer sheet for the answer you have chosen.

Sample 1

In the sentence below, which pronoun would BEST replace the underlined words?

Jamie and Robin went to the park to have a picnic.

- A They
- B Their
- C Them
- D Themselves

Sample 2

Which one is NOT a complete sentence?

- A The brown thrasher is our state bird.
- B The state flower grows in the forest.
- C The state is Georgia.
- D The state tree, the live oak.



1 Andy wants to write a paper about George Washington. Which of the following questions should probably NOT appear in his research?

- A** How did George Washington meet his wife?
- B** How did George Washington become the first American president?
- C** How did he gain the trust of the people?
- D** Why did Washington want to be president?

2 Mark is doing a presentation on the layers of the earth. What resource would give him information on the temperature of the earth's core?

- A** a dictionary
- B** an encyclopedia
- C** a world atlas
- D** *The Readers' Guide to Periodical Literature*

3 LINK/FIELD TEST ITEM

4 When you take notes for a research paper, you can summarize, write direct quotations, or you can paraphrase. Why should you give credit to the author when you copy an author's exact words?

- A** to avoid quoting
- B** to avoid summarizing
- C** to avoid writing
- D** to avoid plagiarizing

5 Jane needs to find another word for *excitement*. What resource would help her the MOST?

- A** a dictionary
- B** a thesaurus
- C** a glossary
- D** an index

6 Where would you look if you wanted to see the sources from which the book you were reading was written?

- A** glossary
- B** bibliography
- C** index
- D** table of contents

7 LINK/FIELD TEST ITEM

8 LINK/FIELD TEST ITEM**9 LINK/FIELD TEST ITEM****10 What is the purpose of the sentence below?**

I can't believe you did this!

- A** make a statement
- B** ask a question
- C** make a request
- D** state a strong feeling

11 Which sentence below is correct?

- A** You can wash and dry the dishes, or you can finish your homework.
- B** You can wash and dry the dishes, you can finish your homework.
- C** You can wash and dry the dishes or, you can finish your homework.
- D** You can wash, and dry the dishes, or you can finish, your homework.

12 If you wanted to add the phrase *on the shelf* to describe the book, where would you place it in the sentence below?

Keesha handed the book to Larry.

- A** before *Keesha*
- B** between *handed* and *the*
- C** between *book* and *to*
- D** after *Larry*

- 13** What is the simple predicate of the sentence below?

Jaleel and his friend should have come to the party.

- A come to
- B should
- C should have come
- D to the party

- 14** Which of the sentences below is an example of an imperative sentence?

- A That play was fantastic!
- B I have twenty-three kids in my class.
- C Do you want another piece of chicken?
- D Turn left at the corner.

- 15** Which word is the predicate nominative in the sentence below?

This number is the correct address of the capitol building.

- A number
- B correct
- C address
- D building

- 16** What is the modifying clause in the sentence below?

The sign hanging on the door told us when the clerk would return.

- A The sign
- B hanging on the door
- C told us when
- D the clerk would return

- 17** LINK/FIELD TEST ITEM

- 18** Which sentence below is a simple sentence?

- A We might arrive late, or we may not come at all.
- B We will try very hard to attend.
- C We will come when we get home from work.
- D We may not come, but we will send a gift.

- 19** What is the function of the underlined word in the sentence below?

The software about artists is quite educational.

- A a direct object
- B an indirect object
- C a predicate adjective
- D a subject

20 LINK/FIELD TEST ITEM**21 What change should be made to the sentence below?**

Corey gave a full complete account of the newspaper staff's activities at the Young Journalists Convention.

- A omit *account*
- B omit *full*
- C omit *staff's*
- D omit *convention*

Use the paragraph below to answer question 22.

¹Trying new foods can bring a sense of adventure into your daily routine. ²On the other hand, this adventure can be disappointing because you end up trying some foods that just taste weird. ³Nevertheless, what would it be like to know only vanilla ice cream? ⁴Vanilla, however, was looking good to me last night, when my tongue was introduced to a taste I hope never to meet again: clove-flavored ice cream.

22 What is the purpose of the underlined transitions in the paragraph above?

- A to show similarity
- B to show contrast
- C to show consequence
- D to show sequence

23 Which words can you take out of the paragraph below in order to eliminate repetition of an idea?

Everyone has different activities to start the day. My sister Karla reads the newspaper, while my mom and dad discuss what they expect to do at work. My cat probably thinks about how she's going to sleep on the couch when no one is around. But I like nothing better than to listen to the radio in the morning hours before noon.

- A different activities
- B what they expect to do
- C going to sleep
- D hours before noon

24 LINK/FIELD TEST ITEM

Use the paragraph below to answer question 25.

¹The German Shepherd is a beautiful dog.
²It is considered one of the more intelligent dogs.
³The coat of a German Shepherd is typically black, varying shades of brown, or a mixture of brown and black. ⁴The tall height and powerful build give the dog a commanding appearance.

25 Which sentence should be removed from the paragraph above?

- A** sentence 1
- B** sentence 2
- C** sentence 3
- D** sentence 4

Use the paragraph below to answer question 26.

¹Slowly, Ezra made his way up the steep steps.
²With each stair he climbed, Ezra could feel his confidence swelling. ³He approached the classroom door feeling determined to do well. ⁴He had studied hard, motivated by the knowledge that once he passed this test, summer would begin and his time would be free.

26 In the paragraph above, after which sentence should the following sentence BEST be added?

Arriving at the top of the stairwell, Ezra turned left.

- A** after sentence 1
- B** after sentence 2
- C** after sentence 3
- D** after sentence 4

Use the paragraph below to answer question 27.

¹Grandma had a beautiful, eight-piece antique canister set on her countertop painted on the sides and top of each piece were pink, blue, and yellow flowers. ²Written on the front was a word telling what the particular canister was supposed to hold. ³*Oatmeal, Barley, Sugar, and Tea* were on the big canisters, while *Nutmeg, Cinnamon, Pepper, and Salt* were on the small ones. ⁴I guess people didn't use much flour in those days.

27 Which sentence in the paragraph above is a run-on?

- A sentence 1
- B sentence 2
- C sentence 3
- D sentence 4

28 LINK/FIELD TEST ITEM

29 Which words **BEST** fill in the blanks in the sentence below?

The wind _____ and _____, sounding like a lonely ghost seeking a place to rest.

- A whistled, yelled
- B howled, moaned
- C growled, roared
- D blew, blew

Directions:

Each sentence below has a spelling error. Fill in the circle on your answer sheet for the letter of the underlined word that is NOT spelled correctly.

30 The aplicant/ confidently/ boasted/ about his résumé.
A B C D

31 LINK/FIELD TEST ITEM

32 LINK/FIELD TEST ITEM

33 LINK/FIELD TEST ITEM

34 LINK/FIELD TEST ITEM

35 LINK/FIELD TEST ITEM

- 36** Which word is a misplaced modifier in the sentence below?

The chorus group enjoyed really the picturesque scenery in Green Valley.

- A chorus
- B really
- C picturesque
- D Green

- 37** LINK/FIELD TEST ITEM

- 38** What is the BEST way to combine the sentences below?

Robert Frost is one of America's best-known poets. Much of his poetry describes nature. His poems are often set in New England.

- A Robert Frost, one of America's best-known poets, describes nature in much of his poetry and often sets his poems in New England.
- B Even though much of his poetry describes nature, Robert Frost is one of America's best-known poets that often sets his poems in New England.
- C Because his poems are often set in New England; Robert Frost is one of America's best-known poets whose poetry describes nature.
- D With much of his poetry describing nature whose poems are often set in New England, Robert Frost is one of America's best-known poets.

- 39** Which answer is correctly punctuated and uses the proper connective to combine the sentences below?

Jessie is informed, efficient, and communicative. She will make an excellent student government representative.

- A** Although Jessie is informed, efficient, and communicative, she will make an excellent student government representative.
- B** Because Jessie is informed, efficient, and communicative, she will make an excellent student government representative.
- C** Even though Jessie is informed, efficient, and communicative, she will make an excellent student government representative.
- D** Jessie is informed, efficient, and communicative; whereas, she will make an excellent student government representative.

- 40** What is the proper correction for the sentence fragment below?

Large spruce trees with their fresh-smelling needles.

- A** Large spruce trees standing tall with their fresh-smelling needles.
- B** Large spruce trees stand tall with their fresh-smelling needles.
- C** Very large spruce trees standing tall with their fresh-smelling needles.
- D** Spruce trees standing tall with their fresh-smelling needles.

Use the paragraph below to answer question 41.

¹Our social studies assignment was to interview someone who lived during World War II. ²I picked my great-uncle. ³I picked my uncle because he was in the army in Europe. ⁴He had amazing stories to share about those years.

- 41** Which two of the sentences above should be combined?

- A** sentences 1 and 2
- B** sentences 2 and 3
- C** sentences 3 and 4
- D** sentences 4 and 1

- 42** LINK/FIELD TEST ITEM

- 43** LINK/FIELD TEST ITEM

44 LINK/FIELD TEST ITEM**45 How can the capitalization be corrected in the sentence below?**

Sari was born on January 17, 1984, in the state of Washington.

- A use a small letter *s* in *Sari*
- B use a capital letter *J* in *January*
- C use a small letter *w* in *Washington*
- D use a capital letter *S* in *state*

46 What is the correct set of words to complete the sentence below?

A _____ evening at home will help you relax and _____ your anxieties; _____, you're probably exhausted.

- A quiet, lose, besides
- B quite, loose, beside
- C quite, lose, besides
- D quiet, loose, beside

47 Which sentence below uses a possessive pronoun?

- A It's clear that everyone wants to visit Stone Mountain now.
- B She knew that she had better bring a jacket, or else she would be cold.
- C They're the ones who suggested the trip.
- D Do we have to bring our own lunches?

48 Which word BEST fills in the blank in the sentence below?

Was that egg _____ when you bought it?

- A break
- B breaks
- C broked
- D broken

49 LINK/FIELD TEST ITEM**50 Which word(s) BEST fill(s) in the blank in the sentence below?**

My sister said my room was the _____ mess she had ever seen.

- A worse
- B worstest
- C worst
- D most worst

51 LINK/FIELD TEST ITEM**52 Which sentence below uses a verb (verb form/gerund) as the subject?**

- A** Splashing and diving, the baby seals entertained the onlookers.
- B** The bottling plant was running behind schedule, which delayed the delivery to grocery stores.
- C** To learn two foreign languages takes a great deal of effort.
- D** Jogging seems to have become the favorite form of exercise throughout the world.

53 Which of the following is capitalized correctly?

- A** Dr. Robert q. McMillan
- B** Dr. Robert q. Mcmillan
- C** Dr. Robert Q. McMillan
- D** Dr. Robert Q. Mcmillan

54 Which word(s) BEST fill(s) in the blank in the sentence below?

Several members of our science club _____ at the water plant on weekends.

- A** volunteer
- B** volunteers
- C** volunteering
- D** is volunteering

55 Which word below would most likely be used as an adverb?

- A** blindness
- B** blindly
- C** blinding
- D** blinded

56 Which sentence below is punctuated correctly?

- A** “Yes,” said the pilot: “we hit a pocket of bad weather.”
- B** “Yes” — said the pilot. “we hit a pocket of bad weather.”
- C** “Yes,” said the pilot, “we hit a pocket of bad weather.”
- D** “Yes”: said the pilot. “we hit a pocket of bad weather.”

- 57** What part of speech is the underlined word in the sentence below?

Synthesis is the combination of parts into a whole.

- A an infinitive
- B a preposition
- C a verb
- D a noun

- 58** What part of speech is *fish* in the sentence below?

There are many different types of fish in this river.

- A possessive form of a noun
- B infinitive form of a verb
- C proper form of a noun
- D plural form of a noun

- 59** Which words BEST fill in the blank in the sentence below?

The mail carrier _____ he spoke daily is retiring.

- A with what
- B with who
- C with which
- D with whom

- 60** Which sentence is correctly punctuated?

- A Atlanta, a beautiful city, has become a popular place to live.
- B Can you remember, when we went to the park where we stopped for our picnic?
- C Your plan, I have decided is the most reasonable solution to my problem.
- D The paper Janet, pointed out contained many misspelled words.

Mathematics

Directions:

Today you will be taking the *Mathematics Criterion-Referenced Competency Test*. The Mathematics test consists of multiple-choice questions. Sample questions have been included. Look at the directions for the multiple-choice questions.

There are several important things to remember:

- 1 Read each question carefully and think about your answer. Then choose the answer that you think is best and fill in the circle for your answer on your answer sheet.
- 2 If you do not know the answer to a question, skip it and go on. You may return to it later if you have time.
- 3 Fill in the correct circle for your answers on your answer sheet only.
- 4 Below are formulas you may find useful as you work the problems. However, some of the formulas may not be used. You may refer to this page as you take the test.

Formulas

Area

Rectangle and Parallelogram

$$A = b \times h$$

Triangle $A = \frac{1}{2} \times b \times h$

Circle $A = \pi \times r^2$

Circumference

$$C = \pi \times d$$

$$\pi = 3.14$$

Volume

Rectangular prism $V = l \times w \times h$

Cube $V = s^3$

Cylinder $V = \pi \times r^2 \times h$

Sample Multiple-Choice Questions

Look at the sample test items that follow. These items will show you what the questions in the test are like and how to fill in your answers on your answer sheet. For this type of question, you will select the answer and fill in the circle in the space on your answer sheet for the answer you have chosen.

Sample 1

13 boys and 14 girls are in Mr. Brown’s class. All of them went on a field trip. Which number sentence shows how many students went on the trip?

- A** $14 - 13$
- B** $14 + 13$
- C** $27 - 13$
- D** $27 - 14$

Sample 2

Which one of these numbers is four hundred fifty-eight?

- A** 458
- B** 4,058
- C** 40,580
- D** 400,580

THIS PAGE IS INTENTIONALLY LEFT BLANK.

1 What is the prime factorization of 315?

- A $3^2 \times 5$
- B $3^2 \times 5 \times 7$
- C $3 \times 2 \times 5$
- D $3 \times 5 \times 5$

2 What is $|-43|$?

- A 34
- B -34
- C 43
- D -43

3 LINK/FIELD TEST ITEM

4 How does the area of rectangle $ABCE$ compare with the area of parallelogram $ABDF$?

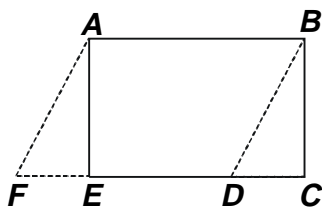

- A The area of rectangle $ABCE$ is greater.
- B The area of parallelogram $ABDF$ is greater.
- C The areas are equal.
- D Not enough information is given to decide.

5 LINK/FIELD TEST ITEM

6 Which two sports cars accounted for exactly 50% of sales?

SPORTS CAR SALES FOR THUNDER EAGLE AUTO

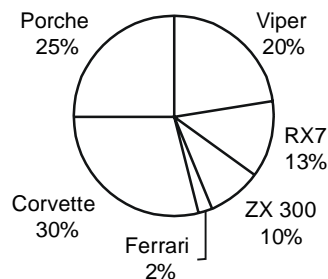

- A Porsche and Viper
- B Viper and Corvette
- C Viper and RX7
- D Porsche and ZX 300

7 What are the factors of 12?

- A 1, 2, 3, 4, 6, 12
- B 1, 2, 5, 8, 10, 12
- C 12, 14, 16, 18, 20, 22
- D 12, 24, 36, 48, 60

8 During the basketball game, Bonnie made 9 shots out of 12 attempts. What percent did she make?

- A 70%
- B 75%
- C 80%
- D 85%

9 LINK/FIELD TEST ITEM

12 LINK/FIELD TEST ITEM

10 LINK/FIELD TEST ITEM

13 LINK/FIELD TEST ITEM

11 LINK/FIELD TEST ITEM

14 LINK/FIELD TEST ITEM

15 In Lan’s class, 24 of the 32 students went on a field trip. What percent of the group went on the trip?

- A** 25%
- B** 50%
- C** 75%
- D** 150%

16 LINK/FIELD TEST ITEM

17 Evaluate $-\sqrt{81}$.

- A** -81
- B** -9
- C** 9
- D** 81

18 LINK/FIELD TEST ITEM

19 What is the frequency of numbers above 55?

43, 55, 41, 50, 52, 56, 44, 48, 55, 52,
41, 41, 54, 55, 42, 45, 59, 49, 44, 49

- A** 8
- B** 6
- C** 4
- D** 2

20 LINK/FIELD TEST ITEM

21 Solve for x .

$$7(x+1) + 3x + 3 = 60$$

- A 2
- B 4
- C 5
- D 9

22 Find the measure of angle B .

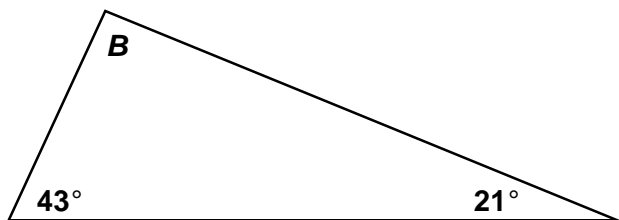

- A 98°
- B 116°
- C 155°
- D 180°

23 In Denver, Colorado, the normal daily high temperatures for 3 months are given in the chart below. If the average of these temperatures including the month of September is 83.5° Fahrenheit, which equation should be used to find the missing temperature?

JUNE	JULY	AUGUST	SEPTEMBER
82° F	88° F	86° F	?

- A $\frac{82+88+86}{3} + x = 83.5$
- B $\frac{83.5}{4} = 82 + 88 + 86 + x$
- C $\frac{4}{82+88+86+x} = 83.5$
- D $\frac{82+88+86+x}{4} = 83.5$

24 Simplify.

$$102 - 3^2 \times 4$$

- A 66
- B 78
- C 138
- D 372

- 25** Mrs. Alvarez’s students took a test. The number of students receiving each score is listed below.

Scores (%)	# of Students
100	2
95	5
85	4
80	2
75	1
70	1

What is the mode?

- A 79
- B 82.5
- C 85
- D 95

- 26** Simplify.

$$\frac{1}{2}(18 + 2) + 2$$

- A 10
- B 12
- C 18
- D 20

- 27** Which digit is in the hundredths place in 713.852?

- A 2
- B 5
- C 7
- D 8

- 28** Which inequality matches the graph?

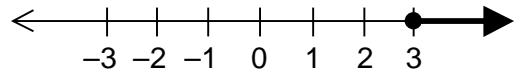

- A $x \leq 3$
- B $x > 3$
- C $x \geq 3$
- D $x < 3$

- 29** Which point is located at (- 3, - 2)?

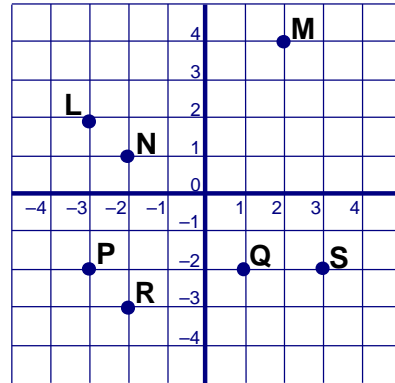

- A L
- B P
- C R
- D S

- 30** Which of the following represents a rotation only of the figure below?

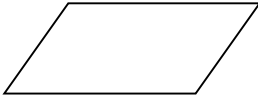

A

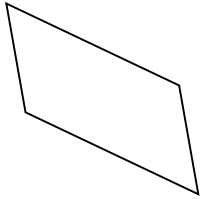

B

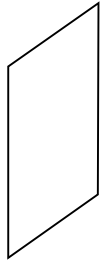

C



D

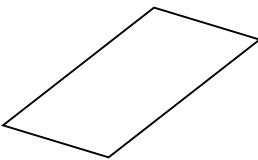

- 31** An architect has made a model of a building, at a scale of 1 inch for every 6 inches. If the arched doorway of the building on the model is 20 inches high, how tall will the arched doorway be on the real building?

- A 10 feet
- B 12 feet
- C 18 feet
- D 20 feet

- 32** How many stuffed animals were sold during the first three months of the year?

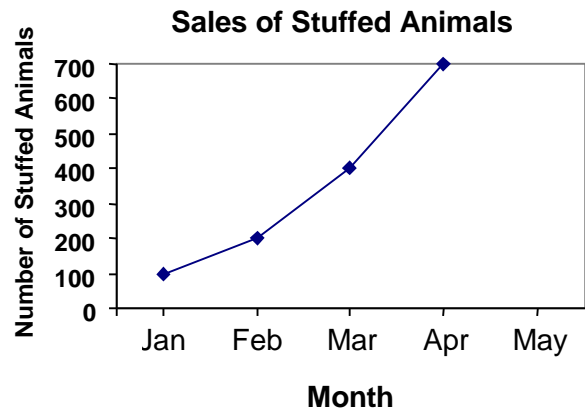

- A 400
- B 600
- C 700
- D 1,200

33 Which is the shaded part as a fraction?

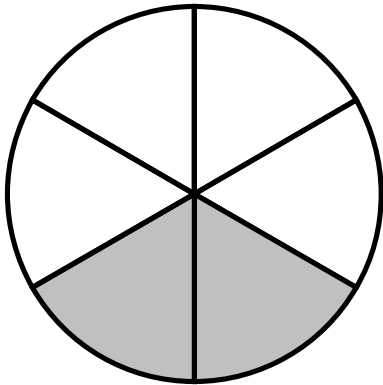

- A $\frac{1}{6}$
- B $\frac{1}{3}$
- C $\frac{1}{4}$
- D $\frac{2}{3}$

34 Which of these represents part of a line with only one endpoint?

- A \overleftrightarrow{YZ}
- B \overline{YZ}
- C \overrightarrow{YZ}
- D YZ

35 Which number goes in the ?

5	9
7	11
8	<input type="checkbox"/>
15	19

- A 10
- B 12
- C 13
- D 18



- 36** Use the graph below to answer the question.

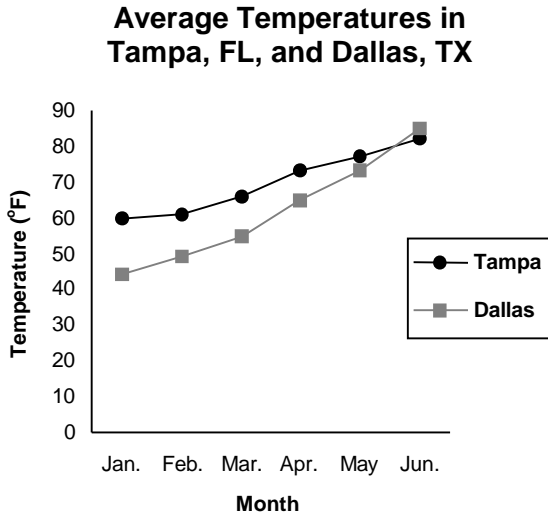

Between what two months does the average temperature in Tampa change the least?

- A** May and June
B March and April
C January and February
D February and March
- 37** Point *X* is located at which point on the number line?

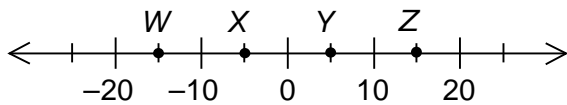

- A** -10
B -5
C 5
D 10

- 38** Complete the pattern.

3,000, 300, 30, 3, 0, .3, _____

- A** .30
B .03
C .003
D .303

- 39** The ratio of cans of orangeade mix to the number of cans of lemonade mix is 4 to 14. If there are 98 cans of lemonade, how many cans of orangeade are there?

- A** 28
B 34
C 43
D 82

- 40** Which boxes have an equal volume?

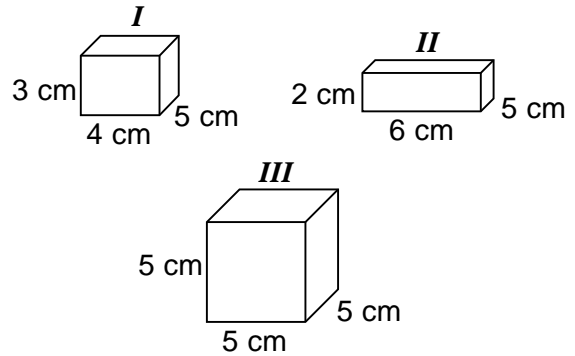

- A** I, II, and III
B II and III
C I and II
D I and III

41 Which always results in a positive number?

- A** the sum of two positive numbers
- B** the difference of two positive numbers
- C** the sum of a negative and a positive number
- D** the difference of a negative and a positive number

42 LINK/FIELD TEST ITEM

43 LINK/FIELD TEST ITEM

44 LINK/FIELD TEST ITEM

45 LINK/FIELD TEST ITEM

46 LINK/FIELD TEST ITEM

47 LINK/FIELD TEST ITEM

- 48 Which was the mean score for the team?

Team Statistics	
Bill	15 points
Jack	20 points
Kenny	25 points
Matthew	15 points
Ray	10 points

- A 15
 B 17
 C 25
 D 85

- 49 LINK/FIELD TEST ITEM

- 50 What is the perimeter of the polygon?

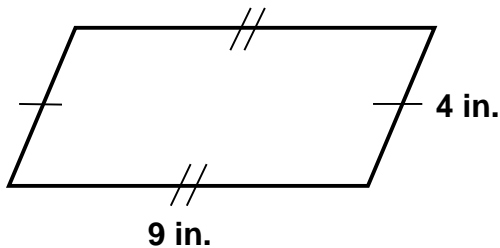

- A 13 in.
 B 26 in.
 C 36 in.
 D 72 in.

- 51 LINK/FIELD TEST ITEM

- 52 Solve for x .

$$542 + (326 + 401) = (542 + x) + 401$$

- A 326
 B 401
 C 868
 D 1,269

- 53 LINK/FIELD TEST ITEM

- 54 What is another way to write $1.495 \cdot 10^3$?

- A 149.5
 B 1,495
 C .001495
 D 1,495,000

55 LINK/FIELD TEST ITEM

56 The scores for the 8th grade team were 4, 5, 7, 3, 4, and 7 for the season. What is their average score?

- A 5
- B 6
- C 7
- D 8

57 LINK/FIELD TEST ITEM

58 The pair of line segments represents the diagonals of a quadrilateral. What is the name of this quadrilateral?

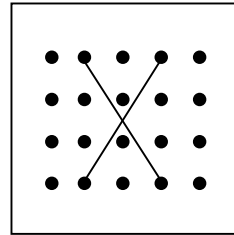

- A rhombus
- B square
- C triangle
- D rectangle

59 Melina is 3 years older than twice José's age. Which of the following represents Melina's age if b represents José's age?

- A $3b + 2$
- B $2b + 3$
- C $2(3 + b)$
- D $3(2 + b)$

- 60** Thelma gave 11 baseball cards to her brother and divided the rest equally among herself and three friends. Her share consisted of 19 cards. How many cards did she have originally?

A 90
 B 87
 C 68
 D 44

- 61** If $x = 7$, what does $3(x - 4)^2 + 18$ equal?

A -9
 B 27
 C 45
 D 99

- 62** Use mental math to solve.

$\frac{3}{6}$ of 1,800

A 9
 B 30
 C 90
 D 900

- 63** Which angle is adjacent to $\angle ABC$?

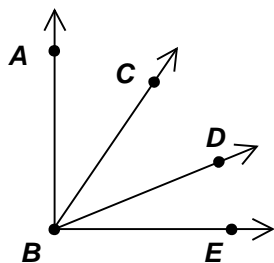

A $\angle ABE$
 B $\angle ABD$
 C $\angle CBD$
 D $\angle DBE$

- 64** Which of the following is a mathematical translation of this phrase: 4 squared times the difference between 18 and 9?

A $4 \times (18 - 9)^2$
 B $4^2(18 - 9)$
 C $4^2 \times 18 - 9$
 D $(4^2 - 18)(4^2 - 9)$

- 65** How is 82,345 written in scientific notation?

A 8.2345×10^4
 B 82.345×10^3
 C 823.45×10^2
 D 8234.5×10^1

- 66** Tom has 4 blue shirts, 5 beige shirts, 6 white shirts, and 3 maroon shirts. His closet is not arranged in any order. If Tom reaches in and pulls out one shirt without looking, what is the probability of it being either a maroon or a blue shirt?

A $\frac{1}{7}$
 B $\frac{3}{18}$
 C $\frac{7}{18}$
 D $\frac{3}{4}$

67 On a test with 20 items, Ellis had a percentage grade of 80%. How many answers did he get right?

- A 15
- B 16
- C 17
- D 18

68 Solve for n .

$$\frac{16}{n} = \frac{4}{7}$$

- A 4
- B 9
- C 12
- D 28

69 If a train goes at an average speed of 80 miles per hour, how long will it take to go 720 miles?

- A 6 hours
- B 7 hours
- C 9 hours
- D 10 hours

70 Which angle is obtuse?

